

PLAN VIEW

ELEVATION VIEW

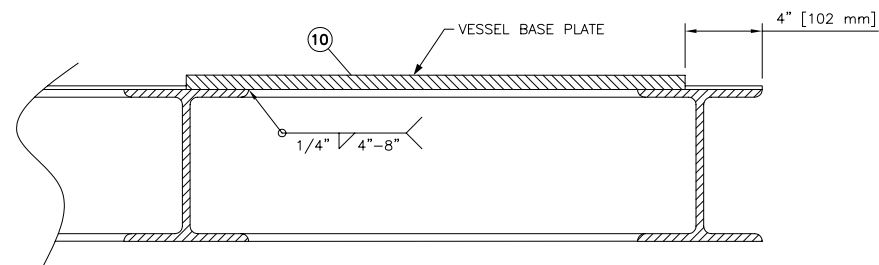

SECTION C  
SCALE: 1:10

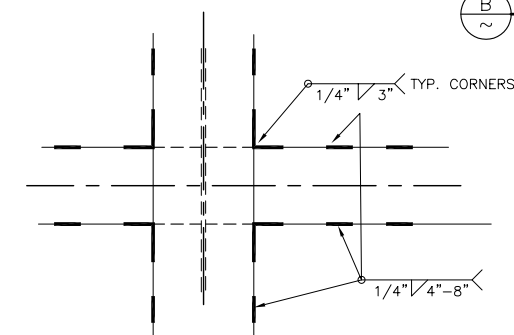

CHECKER PLATE TO SKID  
WELD DETAIL  
SCALE: 1:10

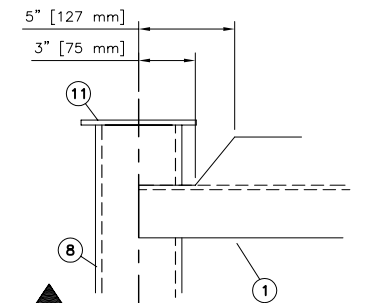

DETAIL A  
SCALE: 1:10  
TYP. 4 CORNERS

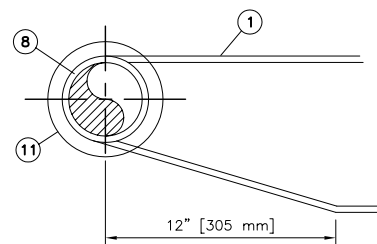

SHOP TO COPE WIDE  
FLANGE TYP. 4 CORNERS

SECTION B  
SCALE: 1:10

BILL OF MATERIAL			
ITEM	QTY.	DESCRIPTION	MAT'L SPEC.
1	2	W8 @ 31 x 240" [6096mm] LG	G40.21-44W
2	2	W8 @ 31 x 87 3/4" [2228mm] LG	G40.21-44W
3	1	W8 @ 31 x 25 3/4" [653mm] LG	G40.21-44W
4	5	W6 @ 9 x 87 3/4" [2228 mm] LG	G40.21-44W
5	1	W6 @ 9 x 40 3/4" [1036 mm] LG	G40.21-44W
6	1	W6 @ 9 x 25 3/4" [653 mm] LG	G40.21-44W
7	5	3 x 2 x 1/4" ANGLE x 40 3/4" [1036 mm] LG (NOTE #3)	SA-36/44W
8	2	4" - SCH 80 SMLS PIPE x 96" [2438 mm] LG	SA-53
9	80 ft <sup>2</sup>	3/16" CHECKER PL (96" WD x 120" LG) [2438mm x 3048mm]	SA-36/44W
10	1	3/4" PLATE - 26" x 26" [660mm x 660mm]	SA-36/44W
11	4	1/4" PL x 6" [152 mm] OD	SA-36/44W

- NOTES:
- 1.) ALL WELDS TO BE 1/4" FILLET WELDS UNLESS OTHERWISE NOTED.
  - 2.) ALL SHARP EDGES & BURRS TO BE REMOVED.
  - 3.) ALL UNEQUAL LEGS ANGLE TO BE INSTALLED LONG LEG DOWN.

REV.	DATE	DESCRIPTION	DRAWN	CHECK	DESIGN	APPR
1	02-MAY-06	CHANGE MATERIAL TO W8@31/W6@9	CB		LM	
0	23-MAR-06	ISSUED FOR CONSTRUCTION	CB		LM	

ULTRAFAB INDUSTRIES LTD.

CLIENT:	ULTRAFAB STOCK
100 BBL DOUBLE WALL TANK / SEPARATOR SKID STEEL DRAWING	

SCALE:	1:30	DRAWING No.	SKID 100SWT	DATE	06-05-02	TIME	13:29
--------	------	-------------	-------------	------	----------	------	-------